

The LPS II range



CLAYTON
POWER

Safety instructions

The Lithium Power Supply (LPS) is classified as Class 9 dangerous goods according to UN3480, a power source with high energy density and hazardous materials in a sealed metal cabinet.

Installation must strictly follow national safety regulations in accordance with the requirements for enclosure, installation, creepage, clearance, marking and segregation requirements for the end-use application. We recommend that installation is performed by authorised professionals. Switch off the system and check for hazardous voltages before changing any connection!

The Lithium Power Supply must only be serviced by trained personnel.

The lowest protection rating for specific parts of the LPS is IP21. Ensure that installation of the Lithium Power Supply complies with IP21 requirements.

This is a Class I product. Connect only 230 V AC from a source connected to protective electrical earth, including all extension cords between source and the device.

In particular, observe these rules:

- When connected to 230V input, voltage is present at 230V output, even when the device is switched off.
- Do not open the Lithium Power Supply.
- Do not discharge a new Lithium Power Supply until it has been fully charged.
- Charge only within the specified limits.
- Make sure the LPS is switched off when moving and installing.
- Do not mount the Lithium Power Supply upside down or on the side.
- Check if the Lithium Power Supply has been damaged during transport.
- Do not series- or parallel-connect lithium power supplies.
- Do not leave exposed to weather.
- Do not cover or block the fan or air intake to ensure that the battery does not overheat.
- Do not allow children or animals to come into contact with the device or connected power supplies.

Danger in case of fire:

- Danger of explosion with dust particles.
- Decomposition due to fire or heat development emits toxic and corrosive gases.
- Combustion gases which strongly irritate the eyes and respiratory organs.

General precautions the driver should observe if these hazards occur:

- Switch off the motor.
- Place a warning sign on the road to warn others.
- Inform others of the dangers and advise them to stay away from the wind direction.
- Contact the police and fire brigade immediately and inform them that lithium batteries (UN3480) are on board.

Instruction for fire extinguishing:

- Extinguish fire with water. If possible submerge the Lithium Power Supply completely in water.
- Extinguishing with water produces fluoride, phosphate, fluoride-oxide and carbon monoxide.
- Alternatively, extinguish with a CO2 fire extinguisher.



**NON-SPILL
LI-ION BATTERY**



Introduction

All information and instructions have been prepared in accordance with current standards, industry guidelines and our many years of experience.

Index

Safety instructions.....	2
Introduction	3
Index	3
Function list	3
In the box	3
Assembly.....	4
Power cable	4
Transport.....	4
Maintenance	4
Service	4
Disposal.....	5
Installation	5
Certifications/compliance.....	5
Safety	5
Basic operation	6-13
Error codes	14-17
Warranty.....	18
Copyright.....	19
Device overview	19
Specifications	20

Function overview

Energy saver AC.....	6
Adjustable AC charging	7
DC shutdown delay	7
Adjustable DC charging	8
Jumpstart	8
Adjustable solar charging	9
Status overview	10
Overview of charging history.....	10
Protection setup	12

In the box

- 1 x LPS charging cable, Neutrik - CEE 7/7
- 1 x AC output (Neutrik grey)
- 4 x Caps for M8
- 4 x M8 screws
- 2 x M4 screws
- 4 x Rubber feet

Mounting

The LPS II must be securely fastened before use. We recommend using Clayton Power LPS II mounting bracket (not supplied as standard) for secure fastening. When installing the LPS II, sufficient space must be left around it to ensure uninterrupted airflow.

NOTE:

The Lithium Power Supply must not be mounted upside down or on the side.

NOTE:

The LPS has forced air cooling. Make sure air can flow freely around the device.

Power cable

A country-specific power cable is included with the LPS II. The cable comes in three different types, UK, Europe or Denmark (UK, EU, DK). Make sure you use the correct cable for the specific area.

Transport

The Lithium Power Supply is classified as class 9 hazardous material according to UN3480 and tested according to UN 38.3. The Lithium Power Supply must always be transported in its original, certified packaging. Transporting the Lithium Power Supply requires trained personnel in accordance with ADR, RID and IMDG, exceptions may apply to private and service transport, check with the relevant authority. For air transport (IATA), the packaging must comply with P965. The original packaging complies. For shipping defective batteries, contact your dealer for more information.

Maintenance

Minimum maintenance is required for the LPS II to perform at maximum. We recommend that you periodically:

Charge your LPS II by plugging it into a 230V socket (not necessary when solar panels are permanently connected).

Make sure all terminals are tightened as specified.

Charge 100% before putting the device into storage. During storage, the device must be fully recharged every 6 months (every 3 months for CL200X) to avoid deep discharge (deep discharge is not covered by the warranty).

Service

Your LPS II contains no parts that can be serviced by the user to maintain the warranty. If you need service, contact Clayton Power or one of our authorised service providers. More details on service options can be found on our website.

Disposal

Batteries bearing the recycling symbol must be processed through a recycling facility approved by an authority in the country concerned. If agreed, the device can be returned to the manufacturer for proper disposal. Batteries must not be mixed with other household or industrial waste.

Installation

You will find an installation diagram enclosed in the LPS II box.

Certifications/compliance

Low Voltage Directive 2014/35/EU

EN62368-1:EU

EMC 2014/30/EU

EN61000-6-2:2019, EN61000-6-3:2007 / A1:2007

UN-ECE Regulation 10

RoHS Directive 2011/65/EU

EN 63000:2018

E-marking

E5 10R – 06 0448

Safety

- 230 V AC input protected with 16 A fuse (non-replaceable)
- 230 V AC output protected by residual current circuit breaker 30 mA | 13 A
(can be replaced by Clayton Power or an authorised service provider)
- DC input protected with 50 A midi fuse
(can be replaced by Clayton Power or an authorised service provider)
- DC output protected with 180 A fuse
(can be replaced by Clayton Power or an authorised service provider)
- Lithium battery protected with fuse (non-replaceable)
- L/N relay hardware protection against hazards.
- PE/N relay hardware protection against hazards.
- Solar panels 20 A fuse
(can be replaced by Clayton Power or an authorised service provider)

Basic operation

Power ON and OFF

Press the power button (12VDC/230VAC/both) on the front of the control panel or the power button on the remote to start the device.

The green LED indicates power ON for either 12VDC or 230VAC.

To turn off the device, press the power button.

Menu

To open the menu, press the "OK" button

Navigate around the menu using the "UP" "DOWN" arrows and "OK" to select and "Back" to go back.

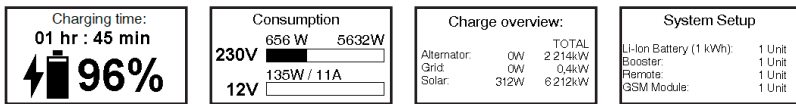

Menu: 230VAC Output

Status:

Operation status: On/Off

Power: (W)att

Voltage: (V)olt

Current: (A)mpere

Functions:

Energy saver

No load

Energy Saver

Threshold

Energy saver: No load

Energy saver no load is an energy saving function that automatically shuts down the LPS II unit if the battery has no load. The factory setting is 1 hour.

It is possible to set the timer or disable it:

Press "OK" to go to menu - Select "230VAC output" - Select "Energy Saver (No load)" and press "OK".

Use the arrows in the Energy Saver window to change the time or set to zero to turn off the function. Press "OK" to activate the selected option.

NB: if you want to connect appliances that only use power once in a while, such as a small refrigerator, you should consider turning off this function.

NB: if using Solar Power, we recommend adjusting or manually switching the energy saver on or off during periods with fewer hours of sunshine. This is to avoid full discharge.

Energy saver: Threshold

The energy saver threshold is part of the save function, which specifies the power load the LPS II must be below before the timer starts. If the current again exceeds the specified level, the timer will reset and only be activated when the current falls below the level again. Factory setting is 20W.

Press "OK" to go to menu - Select "230VAC Output" - Select "Energy saver (Threshold)" and press "OK".

Use the arrows in the energy saver window to change the number of watts or set to zero to turn off the function. Press "OK" to activate the selected option.

Menu: 230 VAC Charging

Status:

Operation status: On/Off

Power: (W)att

Voltage: (V)olt

Current: (A)mps

Functions:

Maximum Current: (A)mpere

Maximum Current

Maximum current makes it possible to control how many amps the LPS II will draw from the built-in battery.

NB: This does not control the direct output that goes through the device. It is important to adapt your appliances to the fuse from which the current is drawn.

Press "OK" to go to menu - Select "230VAC input" - Select "Maximum Current" and press "OK".

Use the arrows in the Maximum Current window to change the maximum number of amps from 1A to 10A. Press "OK" to activate the selected option.

Menu: 12 VDC Output

Status:

Operation status: On/Off

Power: (W)att

Voltage: (V)olt

Current: (A)mps

Functions:

Shutdown time delay: Time

Shutdown time delay

Shutdown time delay is an energy saving function that shuts down the LPS unit according to a set time.

To set or disable the timer:

Press "OK" to go to menu - Select "12VDC output" - Select "Shutdown Delay" and press "OK".

Use the arrows in the Shutdown Delay window to change the time or set to zero to turn off the function. Press "OK" to activate the selected option.

Menu: 12 VDC Charging

Status:

Operation status: On/Off
Power: (W)att
Voltage: (V)olt
Current: (A)mpere
Selected Voltage: 12V/24V

Functions:

Jumpstart functionality: Active/Inactive
Jumpstart: On/Off
Set Reference Volt: Auto/12V/24V
Set Current: (A)mps

Jumpstart functionality Jumpstart functionality is a safety feature that must be enabled before it is possible to use the jumpstart function.

Press "OK" to go to menu - Select "DC Charging" - Select "Jumpstart Functionality"

You can use the arrows in the Jumpstart Functionality window to choose whether the function should be active or inactive. Press "OK" to activate the selected option.

Jumpstart

Press "OK" to go to menu - Select "DC Charging" - Select "Jumpstart" and press "OK".

Move to space between Jumpstart and press "OK". After activating Jumpstart, it will be possible to start the vehicle after about 4 minutes.

Set Reference Voltage

In the function "Set Reference Voltage" it is possible to change the Volt DC load. The factory setting will be Auto, where the device detects the charge voltage itself. In some cases, the LPS II may have difficulty detecting the charge correctly, hence it can be changed manually to 12V or 24V.

Press "OK" to go to menu - Select "12VDC Output" - Select "Set Reference Voltage" and press "OK".

Use the arrows in the Set Reference Voltage window to choose between Auto, 12V or 24V. Press "OK" to activate the selected option.

The selected voltage can be viewed from the "DC Charging" menu under Selected Voltage.

Set Current

In "Set Current" you can change current load, which allows you to adapt the number of amps to external fuses in the installation.

Press "OK" to go to menu - Select "DC Output" - Select "Set Current" and press "OK".

Use the arrows in the "Set Current" window to change the maximum number of amps from 0A to 45A. Press "OK" to activate the selected option.

Menu: Solar

Status:

Operation status: On/Off

Power: (W)att

Voltage: (V)olt

Current: (A)mps

Functions:

Set Operation: ON/OFF

Self-learning OC Voltage: (V)olt

Self-learning MPPT Voltage: (V)olt

Self-learning Start Voltage: (V)olt

Set Operation

The C2 terminal on the LPS II unit is a multifunctional terminal which includes solar charging. You can therefore choose under "Set Operation" whether the LPS unit itself should control what it detects (Auto), search for solar panels only (OK) or other functions (Off).

Press "OK" to go to menu - Select "Solar" - Select "Set Operation" and press "OK".

Use the arrows to choose between Auto, Off or On in the Set Operation window. Press "OK" to activate the selected option.

To reset all solar parameters back to factory settings, set "Set Operation" to "Off". All parameters will switch back to 15V.

If you change solar setup, we recommend that you restore factory settings before reconnecting to the LPS II.

Self-learning OC Voltage

OC Voltage stands for Open Circuit Voltage, which is the maximum voltage a solar panel can deliver without load. The LSP II unit will find this point itself if you do not want to enter a value.

Press "OK" to go to menu - Select "Solar" - Select "Self-learning OC Voltage" and press "OK".

Use the arrows in the Self-learning OC Voltage window to change the maximum number of volts from 15V to 50V. Press "OK" to activate the selected option.

Self-learning MPPT Voltage

MPPT stands for Maximum Power Point Tracking. This means the device can find the most optimal setting to charge most efficiently. It is possible to set this parameter manually.

Press "OK" to go to menu - Select "Solar" - Select "Self-learning MPPT Voltage" and press "OK".

Use the arrows in the Self-learning MPPT Voltage window to change the number of volts from 0.00V to 50V. Press "OK" to activate the selected option.

Self-learning Start Voltage

Start Voltage controls when the LPS II starts charging from the connected solar panels. If the setting is not changed, the LPS II unit will find the most optimal setting itself.

Press "OK" to go to menu - Select "Solar" - Select "Self-learning Start Voltage" and press "OK".

Use the arrows in the Self-learning Start Voltage window to change the maximum number of volts from 0.00V to 50V. Press "OK" to activate the selected option.

Menu: General

Status:

Battery status:
Energy meter:
Temperature:
I/O voltage:

Functions:

Error codes
Display
About

Battery Status

The Battery Status category shows a snapshot picture of device status and performance.

Operation Status Standby:	Standby/On
Remaining Operation:	Time remaining with current load
Current Capacity:	Percent
Power:	W (Watt)
Voltage:	V (Volt)
Current:	A (Amps)
Temperature:	OC (Celsius)
Cell 1:	V (Volt)
Cell 2:	V (Volt)
Cell 3:	V (Volt)
Cell 4:	V (Volt)
Number of cycles:	#Amount

Energy Meter

Under the Energy Meter category, you can see how many kWh have been charged through the 4 terminals.

230VAC Charging:	kWh	kilowatt hours
DC Charging:	kWh	kilowatt hours
DC Output/Super Charge:	kWh	kilowatt hours
Solar:	kWh	kilowatt hours

Temperature

The temperature can be read here for each of the 5 temperature sensors inside the device.

Transformer:	C	Degrees Celsius
IGBT Module:	C	Degrees Celsius
Between Cell 1 and 2:	C	Degrees Celsius
Between Cell 2 and 3:	C	Degrees Celsius
Between Cell 3 and 4:	C	Degrees Celsius

I/O Voltage

I/O Voltage shows how many volts are on the 5 terminals.

Remote:	V (Volt)
Data:	V (Volt)
Data front:	V (Volt)
C1 terminal:	V (Volt)
C2 terminal:	V (Volt)

Error Codes

Warnings/errors will be listed under "Error Codes". Warnings and errors will disappear from the list when they are resolved.

Press "OK" to go to menu - Select "General" - Select "Error Codes".

The full error code list can be found here in the user manual under the Error Codes category.

Display

To change the backlight, go to the "Display" menu. You can decide if it should be on, off or shut off up to one hour after.

Press "OK" to go to menu - Select "General" - Select "Display".

Backlight - Charge:	Off/Time/On
Display - Discharge:	Off/Time/On
Parameter protection:	Set Code
Contrast:	30%-100%

Backlight – Charge

You can set the brightness level on the display while the LPS II is charging here.

Press "OK" to go to menu - Select "General" - Select "Display" - Select "Backlight - Charge"

Use the arrows in the Backlight - Charge window to change the timer or switch the backlight on/off. Press "OK" to activate the selected option.

Display – Discharge

You can set the brightness level on the display while the LPS II is discharging here.

Press "OK" to go to menu - Select "General" - Select "Display" - Select "Display - Discharge"

Use the arrows in the Backlight - Discharge window to change the timer or switch the backlight on/off. Press "OK" to activate the selected option.

Parameter Protection

Press "OK" to go to menu - Select "General" - Select "Display" - Select "Parameter Protection"

Use the arrows in the "Parameter Protection" window to select the desired code. After each number press "OK" to move to the next number.

Press "OK" to activate the selected option. Locked parameters will have a key icon.

Each time you want to change one of the locked parameters, enter the self-selected code. The code for all parameters will be turned off for 60 seconds before the device requires it again. To change/delete the code, go to "Parameter Protection" to reset the code. A new one can be entered.

Contrast

The display's contrast can be adjusted here.

Press "OK" to go to menu - Select "General" - Select "Display" - Select "Contrast"

Use the arrows in the "Contrast" window to change contrast from 30% - 100%. Press "OK" to activate the selected option.

Sound

You can adjust the sound level for the LPS II here.

Press "OK" to go to menu - Select "General" - Select "Sound"

Power:	Off/On
Button:	Off/On
Error:	Off/On

Sounds for Power on and off, navigation buttons and error codes can be activated/deactivated.

About

The "About" menu contains basic information on your LPS II device.

Press "OK" to go to menu - Select "General" - Select "About".

The information is as follows:

Serial Number:	30XXXX-1234
Manufactured:	2021-01-01
Hardware version:	30:00
Firmware version - Unit:	01:30:30
Firmware version - Display:	01:04:07
Firmware version - Power Board:	91:00:07
Firmware version - DC-DC:	01:00:30

Service - QR Code

A QR code can be scanned in the Service category that will take you directly to Clayton Power's service page. On the service page, you will find all manuals as well as tips and tricks for different installations and uses.

Operation via Remote

Charging

It is possible to read if the device is charging and from which source. This is by a diode lighting up from one of the three charging options (230V, 12V, 12V Boost).

Power ON/OFF

To activate the LPS II, press the desired voltage, 230V/12V, or both. On correct start-up, a green diode will light according to the selected voltage.

Jump start

Activate jump start by pressing the button, after which a green LED will flash. After about 4 minutes it will be possible to start the vehicle.

Battery status

The LPS II battery level can be read from the remote control. Battery level is indicated by 5 LEDs, which show how much power is left in the battery.

Error codes

The table contains all error codes and the recommended solution to fix the error.

Error code	Description	Solution
1	EEPROM CRC Error	Contact your dealer for service
2	EEPROM Offline	Contact your dealer for service
3	High voltage	Contact your dealer for service
Temperature		
Error code		
4	Internal electronics are getting too cold	Solution Let the device warm up or move to a place with a higher ambient temperature
5	Internal electronics are too cold to operate	Move to a place with a higher ambient temperature
6	Internal electronics are getting too hot	Let the device cool down or move to a place with a lower ambient temperature
7	Internal electronics are too hot to operate	Move to a place with lower ambient temperature
8, 9	A temperature sensor is broken	Contact your dealer for service
M1Z data error.		
Error code		
11	IO (Remote) is overloaded or short-circuited	Solution Unplug and check plug and cable for damage.
12	IO (DATA) is overloaded or short-circuited	Unplug and check plug and cable for damage.
13	IO (Front) is overloaded or short-circuited	Unplug and check plug and cable for damage.
14	IO (C2) Terminal is overloaded or short-circuited	nplug and check plug and cable for damage
IGBT error		
Error code		
20, 22	IGBT Error	Solution Remove the load and restart the device by holding down the two power buttons for 10 seconds. If a restart does not eliminate the error, contact your dealer for service

Battery cells

Error code	Description	Solution
------------	-------------	----------

30 - 48	Calibration error	Contact your dealer for service
---------	-------------------	---------------------------------

50	No contact with cell	Contact your dealer for service
----	----------------------	---------------------------------

51	Flat battery	Contact charging power for 230Vac, 12VDC or solar
----	--------------	---

52	Voltage of one or more batteries approaching low level	Charge battery
----	--	----------------

53	The voltage of one or more batteries is too low.	Charge battery
----	--	----------------

54	Voltage of one or more batteries approaching high level	Disconnect all charging connectors and give the device time to balance. Contact your dealer if the warning is not gone within 24 hours
----	---	--

55	The voltage of one or more batteries is too high.	Disconnect all charging connectors and give the device time to balance. Contact your dealer if the warning is not removed within 24 hours
----	---	---

56	One or more cells are becoming undercooled	Place the device in higher ambient temperature
----	--	--

57	One or more cells are undercooled	Place the device in higher ambient temperature
----	-----------------------------------	--

58	One or more cells are overheating	Allow the device to cool or place at a lower ambient temperature.
----	-----------------------------------	---

59	One or more cells are overheated	Allow the device to cool or place at a lower ambient temperature.
----	----------------------------------	---

60	Total battery voltage too low (Volts)	Charge battery
----	---------------------------------------	----------------

Solar

Error code	Description	Solution
------------	-------------	----------

70	Solar overvoltage	Check if the installation is correct and does not exceed the max voltage of 55V
----	-------------------	---

71	Solar overcurrent	Check if the installation is correct and does not exceed the max amps of 50A
----	-------------------	--

72	Solar blown fuse	Contact your dealer
----	------------------	---------------------

DC

Error code	Description	Solution
------------	-------------	----------

88	Warning DC overload, error may occur	Remove DC-out load
----	--------------------------------------	--------------------

89	Jump start was interrupted	Check for other error codes
----	----------------------------	-----------------------------

90	DC input voltage too low to charge the battery	Provide higher 12VDC voltage to charge the device.
----	--	--

91	DC input voltage is too high to charge the battery	Provide lower 12VDC voltage to charge the device.
----	--	---

92	DC/DC Input voltage too low	DC Input voltage is low and DC charging is paused
----	-----------------------------	---

93	DC/DC does not work as expected	Contact your dealer for service
----	---------------------------------	---------------------------------

94	DC Output relay connection error	Contact your dealer for service
----	----------------------------------	---------------------------------

95	DC Output relay out-of error	Contact your dealer for service
96	DC Output (Super charge) charging current is too high	12VDC output has a power source connected which generates an excessive charging current. Remove or adjust the power source
97	DC output discharge current is too high	12VDC output load draws too much current
101	Measurement error AC current	Contact your dealer for service
102	Measurement error DC current	Contact your dealer for service
105	High voltage error	Turn off the LPS II, wait 5 seconds, then turn it on by holding down the two power buttons for 10 seconds. If restart does not eliminate the error, contact your dealer for service.
120	DCDC internal critical error	Turn off the LPS II, wait 5 seconds, then turn it on by holding down the two power buttons for 10 seconds. If restart does not eliminate the error, contact your dealer for service.
121	DCDC master communication	Check cables
122	DCDC Temperature warning	Let the device cool down or move to a place with a lower ambient temperature
123	DCDC Temperature too high	Move the device to a location with a lower ambient temperature
124	DCDC Voltage A too high	Provide lower 12VDC voltage to charge the device.
125	DCDC Voltage B too high	Turn off the LPS II, wait 5 seconds, then turn it on by holding down the two power buttons for 10 seconds. If restart does not eliminate the error, contact your dealer for service.
126	DCDC current A too high	Turn off the LPS II, wait 5 seconds, then turn it on by holding down the two power buttons for 10 seconds. If restart does not eliminate the error, contact your dealer for service.
127	DCDC current B too high	Turn off the LPS II, wait 5 seconds, then turn it on by holding down the two power buttons for 10 seconds. If restart does not eliminate the error, contact your dealer for service.
PSU		
	Error code	Solution
130	PSU Control voltage too low	Contact your dealer for service
131	PSU LVPS error	Contact your dealer for service
132	PSU IGBT temperature sensor error	Contact your dealer for service
133	PSU Mosfet temperature sensor error	Contact your dealer for service
135	PSU Clamp discharge error	Contact your dealer for service
136	PSU Clamp charging error	Contact your dealer for service
137	PSU Transformer Ratio	Contact your dealer for service
138	PSU 400V Feedback	Contact your dealer for service
139	PSU 400V too high	Contact your dealer for service

140	PSU communication timeout	Contact your dealer for service
141	PSU communication timeout	Contact your dealer for service
142	PSU does not work as expected	Contact your dealer for service
230 VAC		
Error code	Description	Solution
150	230VAC Output overloaded	230VAC output is overloaded. Load error
151	230VAC Output peak current duration too long	230VAC output is overloaded. Load error
152	230VAC Output peak current too high	230VAC output is overloaded. Load error
153	PE/N relay failure	Contact your dealer for service
154	PE/N relay failure	Contact your dealer for service
155	Overload timer for AC output running overload error may soon occur	230VAC output is overloaded. Load error
156	AC Output not working as expected	230VAC output is overloaded. Load error
AC Input		
Error code	Description	Solution
200	AC charging current too high	Turn off the LPS II, wait 5 seconds, then turn it on by holding down the two power buttons for 10 seconds. If restart does not eliminate the error, contact your dealer for service.
202	Internal high voltage fault	Turn off the LPS II, wait 5 seconds, then turn it on by holding down the two power buttons for 10 seconds. If restart does not eliminate the error, contact your dealer for service.
203	230 VAC Output overloaded	Turn off the LPS II, wait 5 seconds, then turn it on by holding down the two power buttons for 10 seconds. If restart does not eliminate the error, contact your dealer for service.
204	Transfer relay error	Contact your dealer for service
205	Transfer relay error	Contact your dealer for service
206	230 VAC voltage from the mains is too low.	230VAC charge is too low. Check plug or try another socket.
207	230 VAC voltage from the mains is too high.	230VAC charge is too high. Check plug or try another socket.
208	AC Input general error	Contact your dealer for service

Warranty

IMPORTANT AND WARNING:

DO NOT USE OR ATTEMPT TO USE THIS PRODUCT UNTIL YOU HAVE READ THE USER MANUAL IN ITS ENTIRETY. IMPROPER INSTALLATION OR USE OF THIS DEVICE MAY BE DANGEROUS AND MAY CAUSE DAMAGE TO OTHER ELECTRICAL EQUIPMENT AND WILL VOID THE WARRANTY.

Clayton Power warrants, to the original purchaser only, for a period of 24 months from the date of purchase, that the Clayton Power unit will be in good working order when properly installed and operated as described in this manual.

If the device fails within this time period under normal use, Clayton Power will, without charge, at a location of Clayton Power's choosing, repair or replace the device as Clayton Power deems necessary.

The warranty will not apply in the event of:

Use contrary to the recommendations in this manual.

Use in applications outside of general automotive, solar, industrial or marine applications without the agreement of Clayton Power.

Modification or repair of the device without written approval from Clayton Power.

Reverse polarity, extensive overload, general misuse, carelessness, wear, ingress of liquids (water, oil, acid or other), foreign bodies, lightning, over or under voltage, electromagnetic noise/interference, etc.

Use of warranty service:

To obtain warranty service, contact the store where you bought our product. Do not contact Clayton Power directly. Inform/show the following at the warranty service:

- Sales receipt
- Device model number
- Device serial number
- A brief description of the application and the problem including error codes displayed on the device.
- Please contact your Clayton Power dealer for an authorisation number before dispatch - do not send without authorisation.

Once you have received this number, carefully package your device and send it (freight paid) to the Clayton Power dealer.

- Please note that the device contains lithium batteries and must be shipped as dangerous goods according to UN3480 lithium-ion batteries.

Copyright

The information in this document remains the sole property of Clayton Power. No part of this document may be copied or reproduced in any form or by any means, and the information contained herein may not be communicated to third parties without the prior written consent of Clayton Power.

Device overview

Front

- 1 Display
- 2 12 V DC on/off switch
- 3 230 V AC on/off switch
- 4 Down button
- 5 Up button
- 6 OK/Menu
- 7 Return
- 8 M12 - Data, front
- 9 Serial number
- 10 Fault current circuit breaker
- 11 230 output - Schuko plug
- 12 Air cooling - front

Rear

- 13 Air cooling - rear
- 14 DC OUT
- 15 DC IN
- 16 M12 - Remote
- 17 M12 Data
- 18 C1 (D+)
- 19 C2 (Solar +)
- 20 Type plate
- 21 AC OUT
- 22 AC IN

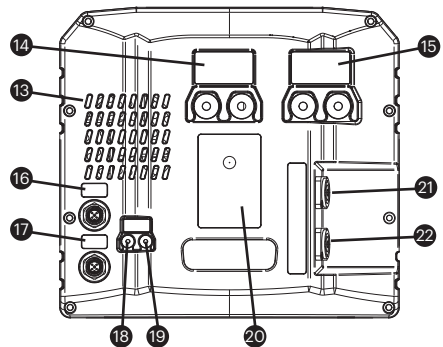
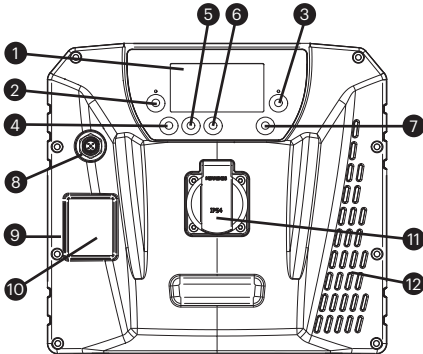

Specifications

Model name:	LPS II 1500 - 1 kWh	LPS II 2500 - 1 kWh	LPS II 3000 - 2 kWh
Model no.	CL2001/CL2101	CL2002/CL2102	CL2003/CL2103
Battery type	Li-ion 12 V - 100 Ah	Li-ion 12 V - 100 Ah	Li-ion 12 V - 160 Ah
Battery chemicals	LiFePO4	LiFePO4	LiFePO4
Battery capacity	100 Ah (1320 Wh)	100 Ah (1320 Wh)	160 Ah (2112 Wh)
Available battery capacity	80 Ah (1050 Wh)	80 Ah (1050 Wh)	136 Ah (1900 Wh)
AC input, voltage	207 - 253 V AC	207 - 253 V AC	207 - 253 V AC
AC input, frequency	45 - 65 Hz	45 - 65 Hz	45 - 65 Hz
AC input, power (charging current)	720 W	720 W	720 W
AC output, voltage + 10%*	230 V AC pure sine wave	230 V AC pure sine wave	230 V AC pure sine wave
AC output, frequency	50 Hz	50 Hz	50 Hz
AC output, power - continuous (ambient temp.)	1300 W	2000 W	2300 W
AC output, power - 10 min.	1500 W	2500 W	3000 W
AC output, power - peak	2600 W	4000 W	5000 W
AC output, power - AC in connected	2300 W	3000 W	3000 W
AC output, efficiency (1000 W)	94%	94%	94%
DC input, voltage	11.5 - 32 V DC	11.5 - 32 V DC	11.5 - 32 V DC
DC input, power	45 A	45 A	45 A
DC input, power with 1 external converter (efficiency)	90 A	90 A	90 A
DC output, voltage	10 - 14.4 V DC	10 - 14.4 V DC	10 - 14.4 V DC
DC output, charging current - continuous	90 A	90 A	90 A
DC output, discharge current - continuous	180 A	180 A	180 A
DC output, discharge current - 1 min.	270 A	270 A	350 A
Solar panel input, charging power (max.)	400 W	400 W	400 W
Solar panel input, voltage	15 - 50 V DC	15 - 50 V DC	15 - 50 V DC
Solar panel input, charging current (max.)	15 A	15 A	15 A
Input signals (5)	C1, C2, M12 x 3	C1, C2, M12 x 3	C1, C2, M12 x 3
Output signals (4)	C2 and M12 x 3	C2 and M12 x 3	C2 and M12 x 3
Self-discharge rate per month	<5%	<5%	<5%
Power consumption - operating mode, DC output only active	<1 W	<1 W	<1 W
Own consumption - operating mode, inverter and DC output in with > 50 W	20 W	30 W	30 W
Connection 230 V AC	Neutrik and Schuko	Neutrik and Schuko	Neutrik and Schuko
Connection C1/C2	M4	M4	M4
Connection DC input	M8	M8	M8
Connection DC output	M8	M8	M8
Cooling	Forced air (blower)	Forced air (blower)	Forced air (blower)
Operating temperature (output will be limited below 0 °C and below)	-20 - 50 °C	-20 - 50 °C	-20 - 50 °C
IP classification	IP21	IP21	IP21
Product weight	22,5 kg	23,5 kg	27,5 kg
Product dimensions (H x W x L)	256 x 277 x 409 mm	256 x 277 x 409 mm	256 x 277 x 409 mm
Jumpstart	40 A/5 min.	40 A/5 min.	40 A/5 min.