



# BEACONS



## ECCOLED SERIES - SILVER

### R65 LED Beacons

The Silver ECCOLED R65 Beacon utilises 9 powerful LEDs, arranged to produce a 360° flash pattern with a flash rate of 125FPM for maximum visibility by using solid-state, maintenance free long-life nature LED technology. This high-performance range has improved EMC, is robust and compact in a popular housing design and is available in five standard mounting options. The ECCOLED range of beacons are suitable for a variety of vehicles including applications where ECE R65 and UK Chapter 8 are a requirement. This range is designed to maximise resilience to excessive vibration, increase the life of the product and is backed by a three-year warranty.

#### Features and Benefits

- R65 Double flash (125FPM)
- Polycarbonate lens with robust base
- Long life LED technology
- Operating Voltage Range 12-24V
- 360° light output
- Current Consumption: 1.5 amps @ 12V
- IP69K option (3 bolt only).

#### Models

PART NO.	VOLTAGE	LEDS	AMPS	MOUNT	COLOUR
EB5014A	12-24	9	1.5	3 Bolt	Amber
EB5015A	12-24	9	1.5	1 Bolt Flexi	Amber
EB5016A	12-24	9	1.5	Mini Din Pole	Amber
EB5017A	12-24	9	1.5	Magnetic	Amber
EB5009A	12-24	9	1.5	Flexi Din Pole	Amber
EB5006G*	12-24	9	1.5	Mini Din Pole	Green
EB5003G*	12-24	9	1.5	Din Pole	Green
EB5004G*	12-24	9	1.5	Magnetic	Green
EB5009G*	12-24	9	1.5	Flexi Din Pole	Green
EB5009R*	12-24	9	1.5	Flexi Din Pole	Red

\*Non R65

#### Dimensions

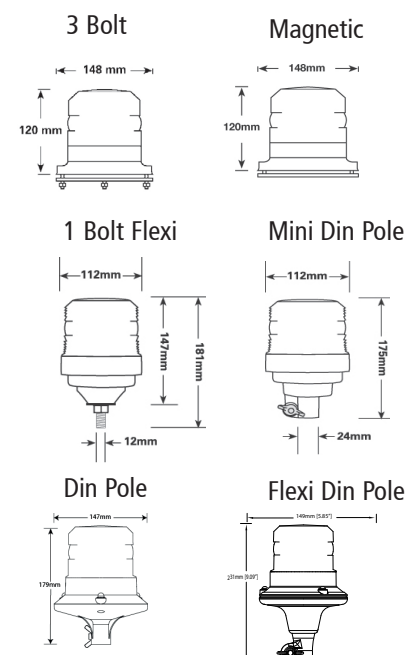

+44 (0)113 237 5340 sales@eccogroup.com